

SDMM3F Development Board

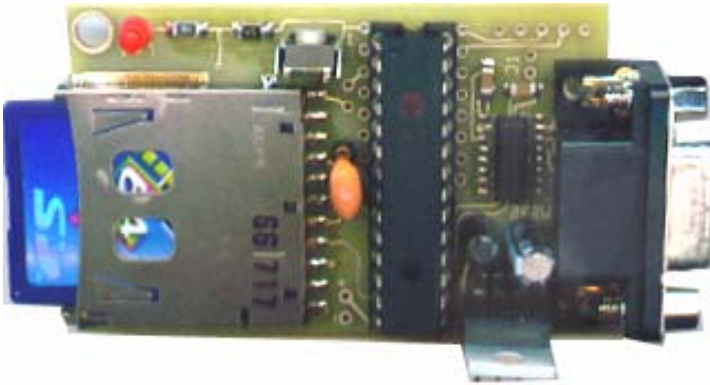

Shown assembled, card not supplied with kit

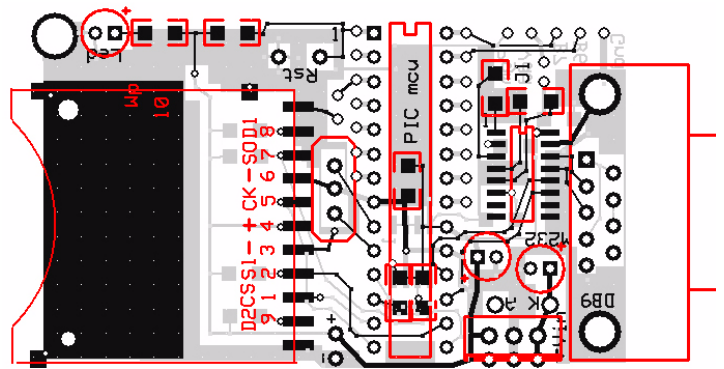

Printed circuit board layout

Parts List

- 7 - 4.7k resistor (SMD)
- 1 - 330 ohm resistor (SMD)
- 6 - 0.1uf capacitors (SMD)
- 1 - 10uf capacitor (radial)
- 1 - 0.1 or 1.0 uf capacitor (radial)
- 1 - LED
- 1 - 10mhz resonator
- 1 - LM2937 3.3v regulator 220case

- 1 - PIC16F876 or PIC18F252 microcontroller
- 1 - Max3232 (or equiv) 16 pin SOIC
- 1 - Ramtron 64kbit I2C FRAM
- 1 - DB9F RS232 female connector
- 1 - SD9 SD/MMC socket (top mount)
- 1 - Momentary reset switch (normally open)
- 1- Printed circuit board

Optional: 1N4001 diode for reverse voltage protection
Misc: header pins

Construction Hints

Assembly of this kit requires that the user has the necessary tools and skills to work with SMD (surface mount device) components. If you are not comfortable with soldering miniature parts, then please seek assistance from someone who is capable to do so. Small mistakes can cause many frustrating hours of grief in trouble shooting!

Minimum tools required:

A fine point low power (25w max) soldering iron and thin solder. Ideally, 0.022" diameter (or less) silver-bearing non-corrosive rosin core should be used. In addition, narrow needle nose pliers, diagonal cutting pliers, good quality tweezers, large magnifying glass, volt-ohm meter, and a 7 to 12 vdc power supply.

Make sure that you work in a clean well lighted area and have adequate desk area. If you have carpeting then please be aware of static discharge as well as accidentally losing tiny components in the carpets fiber. SMD capacitors and resistors are very tiny and can quickly become lost in the carpeting.

Disclaimer and Terms of Agreement

As with any kit, only the individual parts supplied are guaranteed against defects and not the user assembled unit. All kit parts are purchased from reputable sources such as Digikey Inc, Allied Electronics and Mouser Inc, however, should a kit part be ascertained to be defective it will be replaced at no charge within 30 (thirty) days of the purchase date. Beyond that, COMPSys Workbench and / or the COMPSys developer(s) assume no liability and WILL NOT be held liable nor be held responsible wholly or in part for any damages caused by the construction of and / or use of their products sold .

PIC is a trademark name of Microchip Corporation

Construction

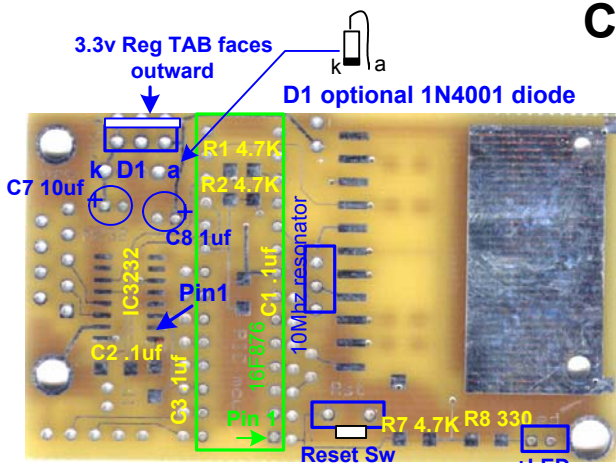

Note orientation of IC3232 and FR2464. PIN 1 is marked with a small dimple on the chip

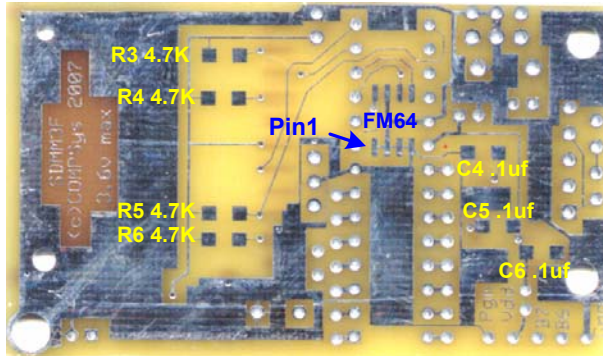

Bottom Side of pcb

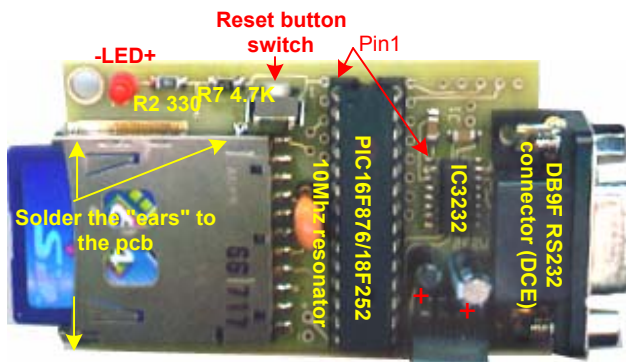

3.3v Reg TAB faces outward

Vin (7-16vDC)

Do Not Reverse Polarity!

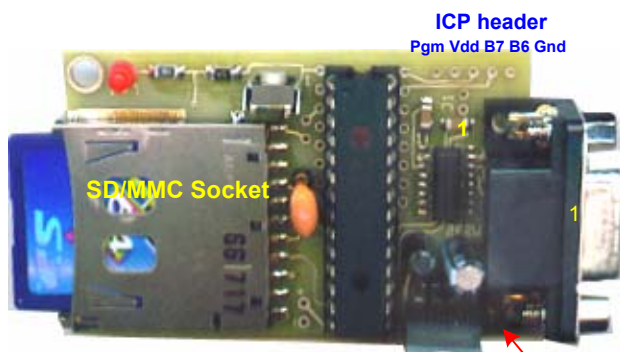

Assembled board (shown with a card)

Optional: Holes (A and K) are available if a diode D1, such as a 1N4001, is needed to protect from reverse voltage

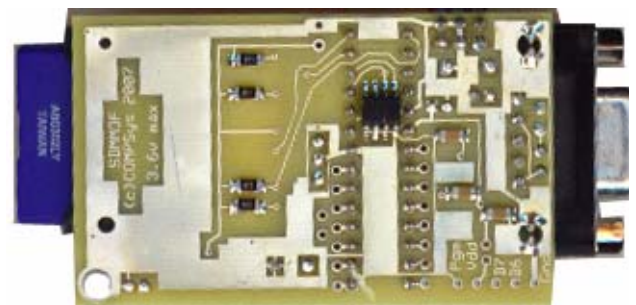

Assembled board backside (shown with a card)

1. Mount and solder all SMD resistors and capacitors. C1-C6 are 0.1uf SMD caps, R1-R7 are 4.7k resistors, R8 is 330 ohm. **Note: R3-R6 and C4-C6 mount on the backside of the pcb**
2. Carefully align and solder the I2C FRAM FM64 (mounted on the backside of the pcb). Make sure to orient the SOIC correctly! Use very little solder!
3. Do the same with the IC3232 SOIC (topside of pcb)
4. Solder the LED. The square pad on the pcb is + and the longer lead of the LED is the anode (+)
5. Mount and solder the 3.3v regulator and. Make sure that the metal **TAB faces the outer edge** of the pcb.
6. Orient and mount the C7 10uf and C8 1uf (or .1uf) radial caps. The longer lead is +. Square pads on the pcb are +
7. Mount the reset switch with the button facing outward and also mount the 10Mhz resonator
8. Carefully align and solder the SD/MMC socket to the top side of the pcb. Make sure that the two plastic bosses mate with the two holes on The pcb. Also tack solder the "ears" for added support.
9. Mount and solder the DB9F and 28 pin IC socket in place.
10. Optionally, mount D1 and solder any header pins that you plan to use.
11. **DOUBLE CHECK ALL YOUR WORK.** Inspect for solder bridges and cold solder joints.

SDMM3F PIC 16F876 3.3volt Schematic

CH1 SD socket contacts layout
9 1 2 3 4 5 6 7 8 9 10 (wp)

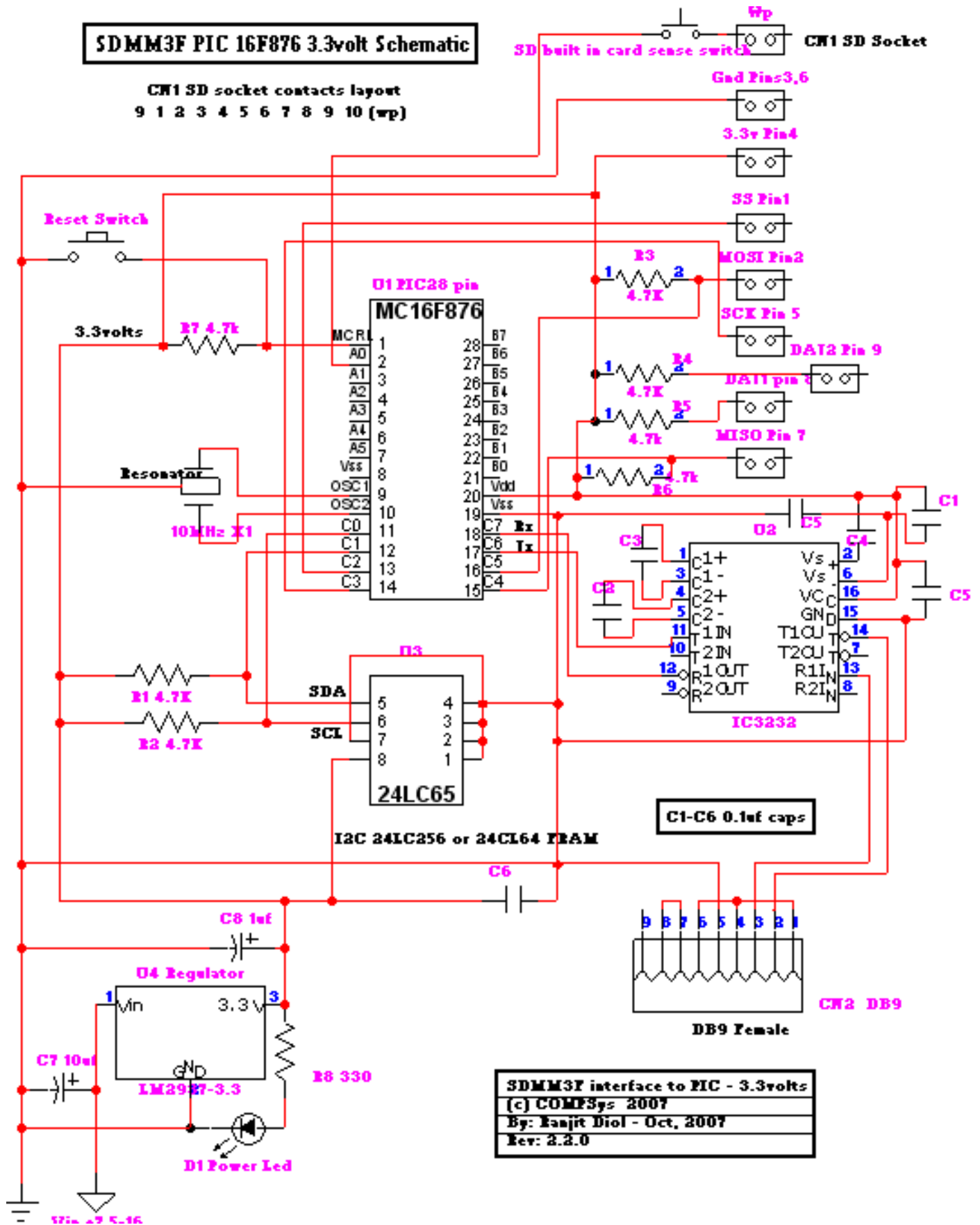

Revisions may be made without notice