

A232DB RS232 adapter kit (3.3v or 5v version)

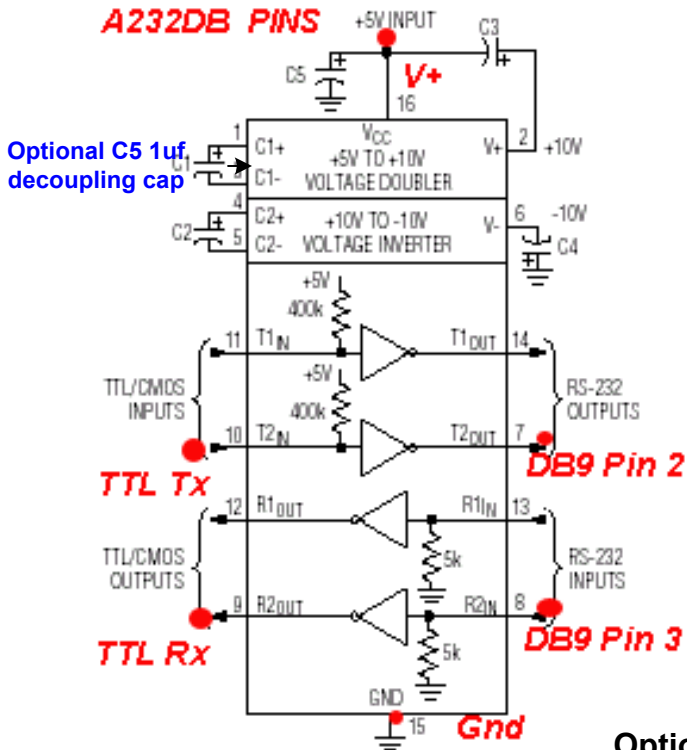
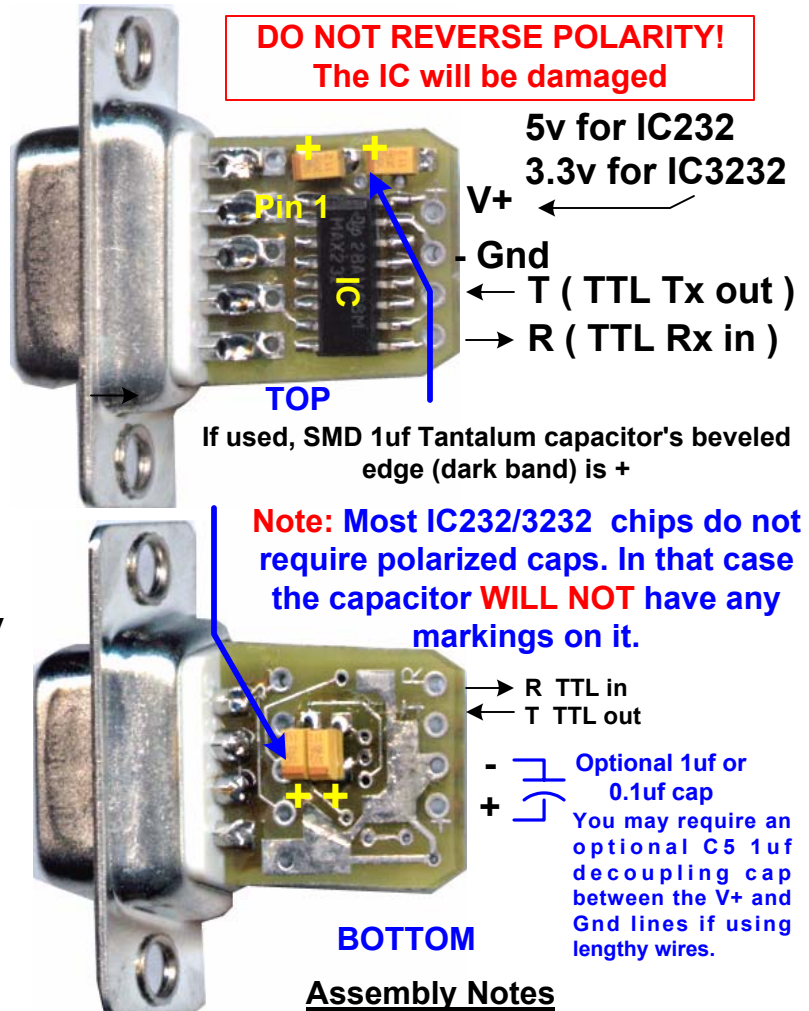
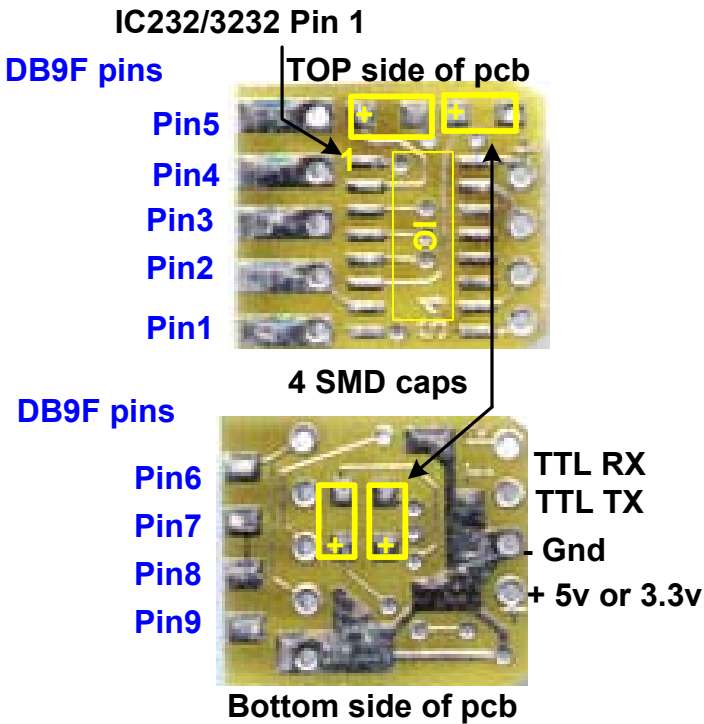

Assembly Notes

Use quality solder approx .020" dia and a fine point soldering iron approx 20w. Carefully mount the SOIC Max232 first observing correct orientation (Pin1 is the 'banded' or 'dimpled' end) . Apply only tiny amounts of solder if needed. Next, install the four SMD capacitors. The beveled edge (dark line) is the positive (+) side of the capacitor. Finally solder the DB9F socket. **Make sure that the top and bottom pins align with the pads and that they do not touch other traces before soldering!** Use a standard RS232 cable with a DB9 connection.

Optionally, the pcb can fit most DB9 shells as shown on the right

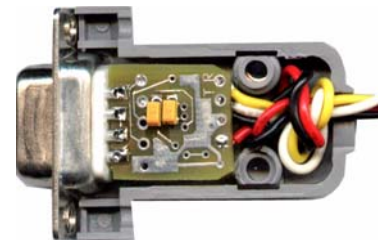

Disclaimer and Terms of Agreement

As with any kit, only the individual parts supplied are guaranteed against defects and not the user assembled unit. All kit parts are purchased from reputable sources such as Digikey Inc, Allied Electronics and Mouser Inc, however, should a kit part be ascertained to be defective it will be replaced at no charge within 30 (thirty) days of the purchase date. Beyond that, COMPSys Workbench and / or the COMPSys developer(s) assume no liability and WILL NOT be held liable nor be held responsible wholly or in part for any damages caused by the construction of and / or use of their products sold .